

# 500 Gallon Spill Leak Containment Vessel

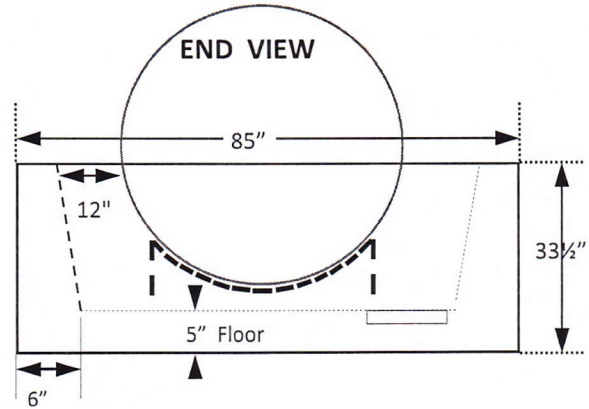

2" Deep Sump.  
Siphon Arrangement Is Provided For The  
Removal Of Rain Water & Spilled Petroleum  
Products.

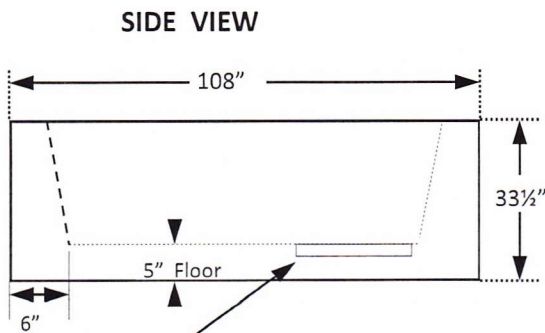
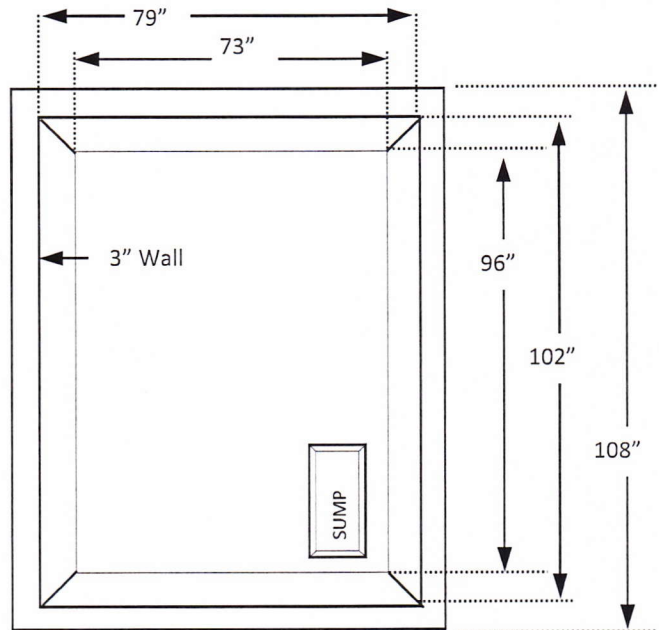

## SPECIFICATIONS

- 1.) Minimum Compressive Strength = 4000 PSI
- 2.) Reinforcements = #4 Rebar 12" On Center In Walls and

## 500 Gallon Spill Leak Containment Vessel

Total Outside Length = 108"

Total Outside Width = 85"

Overall Height = 33 1/2"

Inside Length @ Top = 102"

Inside Length @ Bottom = 96"

Inside Width @ Top = 79"

Inside Width @ Bottom = 73"

Wall Thickness @ Bottom 6" Wall Thickness @ Top = 3"