

1000 Gallon Spill Leak Containment Vessel

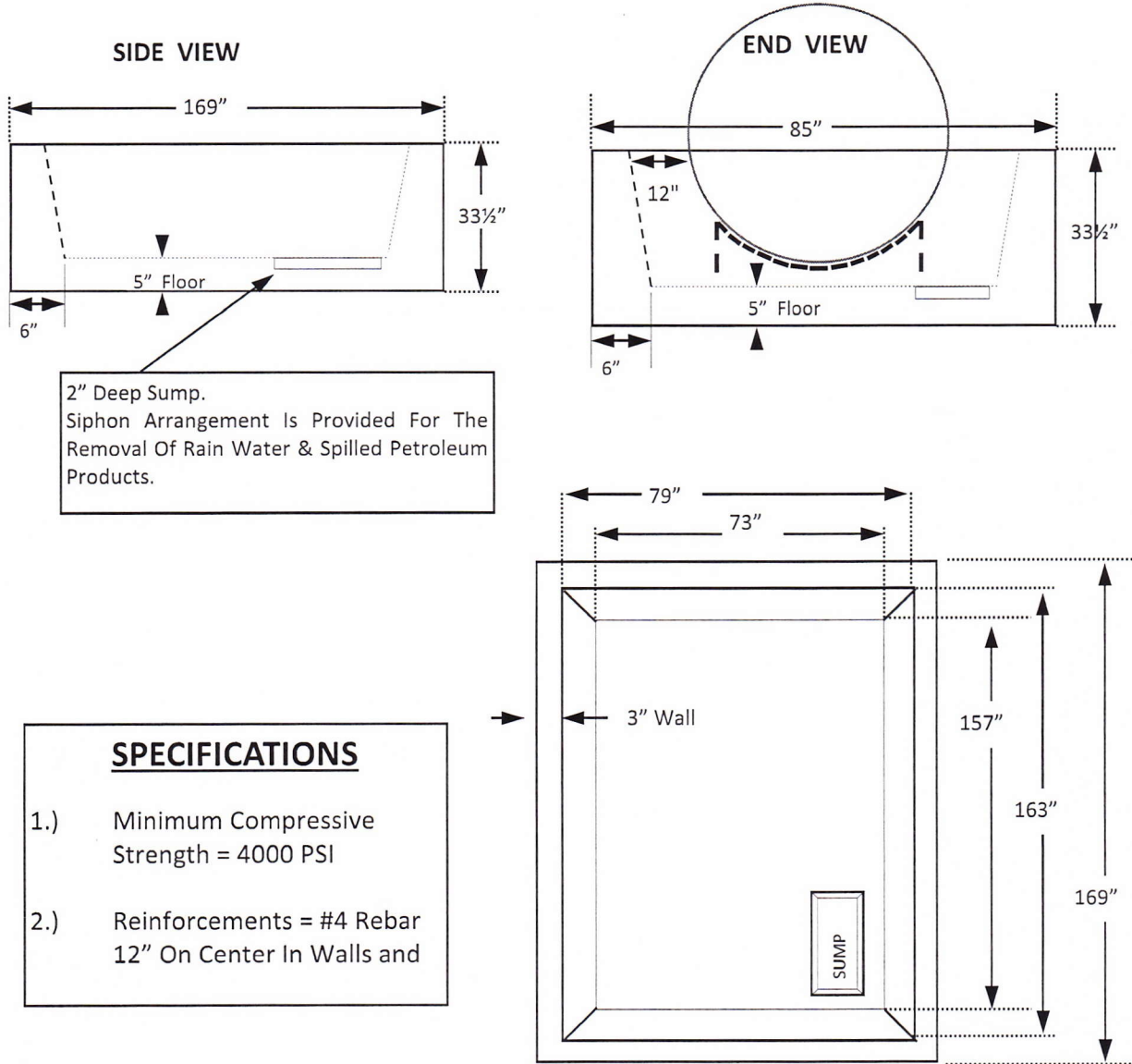

1000 Gallon Spill Leak Containment Vessel

Total Outside Length = 169"
 Total Outside Width = 85"
 Overall Height = 33 1/2"
 Inside Length @ Top = 163" Inside Length @ Bottom = 157"
 Inside Width @ Top = 79" Inside Width @ Bottom = 73"
 Wall Thickness @ Bottom 6" Wall Thickness @ Top = 3"